

3125-320-0900 - CEE - 3x32A / IP67 DÜZ MAKİNE FİŞİ (83x90 FLANŞ)
CEE - 3x32A / PANEL MOUNT APPLIANCE INLET (STRAIGHT)(83x90 FLANGE)(IP67)

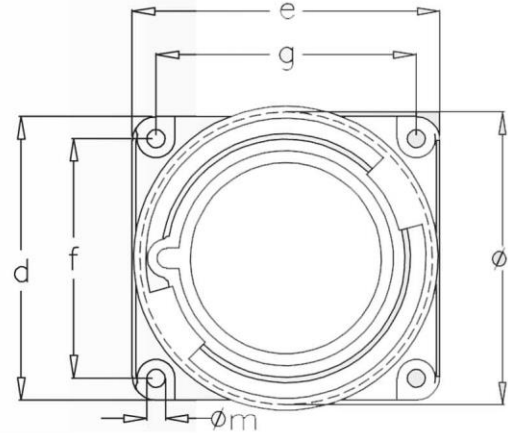

Ambalaj Mik.
Pack Unit

10

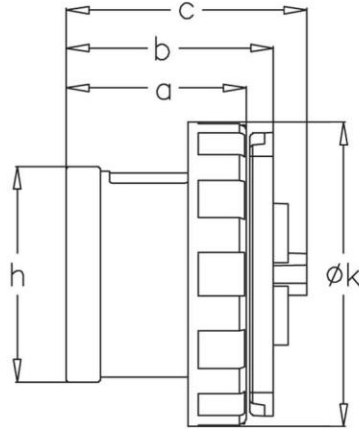

Ağırlık
Weight

160

Ölçüler / Dimensions

a	50	f	70
b	62	g	76
c	65	h	57
d	83	Øm	5.5
e	90	Øk	94
Øl	65		
Kablo Çapı / Cond. Dia. (mm ²) (min.)		2.5	
Kablo Çapı / Cond. Dia. (mm ²) (max.)		6.0	